



Testing the wear of wheelsets of EN97 series vehicles in terms of geometrical parameters of the wheel profile in two-year operation

Wojciech Sawczuk^{a,*} , Armando Miguel Rilo Cañas^b , Sławomir Kołodziejski^b 

^a Faculty of Civil and Transport Engineering, Poznan University of Technology, Poland

^b Doctoral School of Poznan University of Technology, Poland

ARTICLE INFO

Received: 23 July 2023
Revised: 15 August 2023
Accepted: 26 August 2023
Available online: 28 August 2023

KEYWORDS

wheelset
wheel profile
electric multiple unit
operational tests

The article presents the results of wheel wear tests of selected EN97 series electric multiple units. In the tests carried out on the 14 vehicles mentioned above, which were driven on the same route, geometrical parameters of the profile of all wheels were recorded during periodic inspections. The analyzed data concerned the period of over two years of use, when the vehicles were delivered from the manufacturer to the carrier as new. In the form of graphs, cases of exceeding a given parameter in relation to the requirements set in the Maintenance System Documentation are presented, broken down into individual wheelsets. The article presents the results of operational tests, which show which wheel set parameters (wheel diameter, rim steepness, rim thickness, rim height, etc.) are most often exceeded and which are least. The analyzes of the geometric parameters of the wheel profile on the tested group of vehicles, which were used on the same route in the same period, clearly prove that the parameters most often exceeded are wheel diameter and rim steepness. These two exceeded parameters were the basis for turning the wheelsets.

This is an open access article under the CC BY license (<http://creativecommons.org/licenses/by/4.0/>)

1. Introduction

Analyzing the scope of work performed during the operation of electric trucks or diesel multiple units, it is found that the most frequent damage occurs in the running gear, i.e. in wheel sets. For this reason, most of the time is spent on performing the necessary geometrical measurements of the wheelset, filling in the relevant measurement cards in accordance with the template found in the documentation of the DSU maintenance system of a given vehicle, and in the event of wear of any parameter of the wheelset - sending it for repair by rolling or replacing it with a new one [1, 5]. Other assemblies on the trolley, such as traction motors, mechanical transmissions, springing systems or wheelset guiding systems, are characterized by lower wear intensity in accordance with the works than the wheelset rolling on the rail. According to the quoted reliability function $R(t)$ as a function of operation time, in the works of P. Piec [14, 15] it was found that in each period it is possible to rank the reliability of rolling bogie components (assemblies) in

the following order: frame, pivot pins, springing and guiding system, braking system and wheel set with the highest reliability. The found cases of sudden damage to the drive system or cracks, e.g. in the area of bogie frames or other bogie components, were random and could have resulted from system errors made during the design and construction of bogies or resulted from negligence during inspections and repairs of assemblies on rolling or driving bogies. In traction units, depending on the design speed, the number of members with driving and rolling bogies, as well as the load of individual wheelsets, the process of wheel rolling surface wear is not uniform on all wheelsets [18, 20, 21]. The above-mentioned factors affecting the wear of wheelsets result from the design features of the vehicle. The second group of factors that translate into the intensity of wear of the rim surface of the wheels not related to the vehicle is the terrain (mountainous or lowland areas), the number of curves as well as climatic conditions, i.e. driving in winter, autumn or summer [13, 19]. The autumn period is the beginning of difficulties related to rail traffic, when

* Corresponding author: wojciech.sawczuk@put.poznan.pl; (W. Sawczuk)

the rails begin to be wet, often covered with leaves, which translates into difficult start-up and braking, resulting in failure to ensure continuity in the contact between the wheel and the rail. In such situations, when the wheel, without rotating, moves along the rail, the phenomenon of spot abrasion of the wheel surface occurs, commonly referred to as a flat spot. At this point, due to the short-term effect of high temperature, the structure of the circle changes into hard martensite [7, 8]. Further driving of a rail vehicle with flat spots is not recommended due to the deteriorated comfort associated with the cyclical occurrence of acoustic effects at the moment of the wheel with a flat spot hitting the rail. As a consequence, it is necessary to roll the wheel set in the period between periodic inspection cycles and reduce the diameter of the wheel. Unscheduled collection of the wheel material from its diameter will result in shortening the life of the wheel set by reaching the maximum limit wear on the wheel diameter faster. Therefore, it is justified to take such actions aimed at maximizing the service life of the wheelset [9, 11, 12].

The purpose of these tests was to determine, on the basis of the data collected from the geometric measurement cards of the wheelsets, the number of times when a given wheel set parameter was exceeded beyond the tolerance limit specified in the DSU documentation. The study analyzed parameters describing the wheel profile, such as rim thickness and height (O_g , O_w), rim steepness q_R , wheel diameter D and the distance between the inner surfaces of the rim and the distance between the outlines of the rims (A_z and E_z). The results of the analyzes were related to all wheel sets in vehicles.

2. Research object and methodology

The object of the tests was the EN97 electric multiple unit (manufacturer's designation is 33WE), which is designed to handle high-density local passenger traffic. The vehicle consists of two identical tripods connected with each other by a detachable coupler. The axle system of the vehicle is (Bo'2'Bo') (Bo'2'Bo').

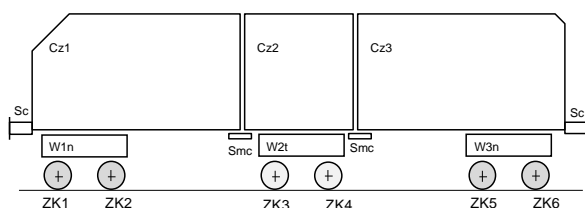

Fig. 1. Scheme of one of the two EN97 three-sections of the vehicle: Cz1 – drive unit with a control cabin, Cz2 – central rolling member, Cz3 – drive unit without a control cabin, W1n, W3n – bogies, W2t – central rolling bogie, ZK1–ZK6 – wheel sets, Sc – front coupler, Smc – inter-unit coupler

The members within the tripartite are connected to each other in a way that ensures a secure connection in operating conditions and the possibility of disconnecting them for the duration of repair works, and they have a passage between them, in accordance with [2–4].

Three-unit type n+t+n (driving unit + rolling unit + driving unit) of the EN97 vehicle are based on three bogies, one person for each unit, the driving extremes and the middle rolling bogie, as shown in Fig. 1. A general view of the electric multiple unit is shown in Fig. 2. Figure 3 shows the view of the vehicle's bogies.



Fig. 2. View of the EN97 vehicle number 001 during service in the inspection and repair hall



Fig. 3. View of the bogies of the EN97 vehicle: a) the 34MN driving bogie disassembled with the transmission and traction motor visible, b) the view of the 4AN rolling bogie under the middle section

The EN97 series vehicle was produced in 14 pieces by PESA Bydgoszcz S.A. The vehicles were delivered to WKD in 2012, the first in January and the last in October. The vehicles were to replace the worn out units of the EN94 series powered by 600 V DC. The total number of vehicle seats is 500, including 120 seats, 376 standing places assuming 5 people per m^2 and 4 places for the disabled. In addition, the vehicle

has an area of 16m² for larger luggage as well as a bicycle rack. An additional advantage of the vehicle is a significant number of entrance doors, i.e. 8 sets per side, which speeds up the exchange of passengers. Additional technical data are included in Table 1.

Table 1. Basic vehicle specifications EN97 (33WE) [2]

No..	Name	Value	Unit
1	Track width	1435	mm
2	Overall assembly length with bumpers	60 000	mm
3	The greatest band width	2 850	mm
4	The greatest height of the assembly from the rail head	4 452	mm
5	Spacing of turning pins	11 750	mm
6	Traction unit power	1440	kW
7	Main circuit voltage	600 V DC/3 kV DC	V/kV
8	Maximum operating speed	80	km/h
9	Acceleration of starting from 0–30 km/h	1.2	m/s ²
10	Braking delay	1.2	m/s ²
11	Empty assembly weight	101.5 ±3%	t
12	The maximum gross weight of the assembly	143	t
13	Wheel set pressure on the track (5 persons/m ²)	140	kN
14	Rolling diameter of wheels (new/worn)	850/780	mm/mm

An important feature that distinguishes both bogies, apart from their purpose, is the wheelbase of the wheelsets (bogie base). In the case of 34 MN drive bogies, the wheelbase is 2300 mm, while in the 43AN bogies – 2100 mm. Two traction motors with a power of 180 kW each are mounted on each driving trolley [3, 4].

When analyzing the basic technical data, it should be noted that the 33 WE vehicle is a dual-voltage unit adapted. The main circuit of the traction motors can be supplied with 3 kV as in the case of railway vehicles (direct voltage) and with reduced voltage, i.e. 600 V as in the case of powering the traction network of trams, due to the fact that older type EN94 vehicles are still available [4].

Reconnaissance tests were carried out on all 14 vehicles of the EN97 series, which were operated from the beginning of service in 2012 for the first 2 years, i.e. until 2014. The vehicles operated on lines no. The study did not include line No. 512 Pruszków–Komorów, due to the fact that there is no scheduled passenger traffic on this line, and the line is a technological link between the WKD line and the railway network managed by PKP PLK S.A. The total length of line 512 is 3.165 km. Figure 3 shows the view of WKD railway lines. Lines 47 and 48 on which passenger traffic takes place are marked red, line 512 is shown in black, and a fragment of the line managed by PKP PLK S.A. is marked in gray.

The total length of the WKD railway line on which scheduled passenger traffic takes place, excluding line 512, is 35,510 km. There are a total of 28 stations and passenger stops on two lines (47 and 48). The average distance between them is 1.2 km. There are 45 category crossings on these lines, with a predominance of category D crossings (29 crossings) and 23 point drives equipped with electric control and automatic heating. Although the maximum speed of vehicles is 80 km/h, the average speed between stations is 36 km/h [16].

Table 2. Basic data on the railway network of the Warsaw Commuter Railway [16]

No.	Line no	Starting and ending station	Line length in km	
			Single-track section	Double-track section
1	47	Grodzisk Mazowiecki Radońska–Warszawa Śródmieście WKD	7.544	25.070
2	48	Podkowa Leśna Główna–Milanówek Grudów	2.896	2
SUM			35.510	

The wheel wear tests of the wheelsets of the EN97 series vehicles were carried out on the basis of the analysis of the results of the geometrical parameters of the wheelsets recorded during the P2 inspection in accordance with the inspection and repair cycle included in the documentation of the maintenance system. Inspection and repair cycles for vehicles are presented in Table 3.

Table 3. Inspection and repair cycles of the EN97 series 33WE electric multiple unit [2]

Lp.	Maintenance level	Maximum mileage in km	Maximum time
1	P1	1800 km	co 72 h
2	P2	12,000 km	30 days
3	P3	125,000 km	12 months
4	P4	500,000 km	4 years
5	P5	1,500,000 km	12 years

Note: inspection and repair work should be initiated depending on the parameter that is achieved first (mileage or number of days).

The purpose of these tests was to determine, on the basis of the collected data from the geometric measurements of the wheelsets, the number of times when a given wheel set parameter was exceeded beyond the tolerance limit specified in the DSU documentation. The analyzed geometrical parameters were the height and thickness of the rim, steepness of the rim, diameter of the rolling circle, the distance between the inner surfaces of the rim in the wheel set without load and the distance between the outlines of the rims, the so-called width leads. On this basis, a ranking of the parameters most often exceeded during geometrical

measurements of wheelsets as a result of rolling wheelsets on WKD tracks was determined.

Table 4. The number of exceeding the parameters of the wheelset beyond the tolerance limits contained in the DSU of the EN97 vehicle number 002A and 002B

	Tripartite 002A					
	Z1	Z2	Z3	Z4	Z5	Z6
Ow	–	–	–	–	–	–
Og	1	1	–	2	–	1
qR	7	6	5	5	2	4
Ogl+Ogp	–	1	–	1	–	–
D	6	4	8	4	2	2
Az	–	–	–	–	–	–
Ez	–	1	–	1	–	1
	Tripartite 002B					
	Z1	Z2	Z3	Z4	Z5	Z6
Ow	–	–	–	–	–	–
Og	1	–	3	–	1	–
qR	8	8	7	4	5	2
Ogl+Ogp	1	–	2	–	–	–
D	5	4	11	8	7	8
Az	–	–	–	–	–	–
Ez	1	–	2	–	–	–
Vehicle mileage	81,190 km					
Lifetime	19.04.2012–03.07.2014					
Number of measurements	20					
Number of ZK transfusions	3					
Courses of transfusions	I – 4385 km, II – 44,800 km, III – 51,465 km					
Ow – rim height (from 25 to 36 mm), Og – rim thickness (from 22 to 33 mm), qR – rim steepness (from 6.5 to 11 mm), Ogl+Ogp – the sum of the thicknesses of the rims of the left and right wheels (from 48 to 66 mm), D – rolling circle diameter (from 780 to 852 mm), Az – distance between the inner surfaces of the rims in the unladen wheelset (from 1357 to 1363 mm), Ez – the distance between the edges of the so-called guiding width (from 1410 to 1426 mm).						

In the case of wheel diameter D, according to the DSU of the vehicle, an additional condition is imposed that the difference between the wheels of the same axle (right and left wheel) may not exceed 1 mm, the difference between the diameters of the wheels in the next wheel set in the bogie may not exceed 2 mm. However, the difference between the individual wheels on the entire vehicle of the electric traction unit may not exceed 5 mm [2]. This condition results from the fact that the wheels wear intensity is similar and the pressures are evenly distributed on individual wheels.

These tests were carried out for all EN97 series vehicles, i.e. for 14 units. Table 4 presents exemplary results for further analysis, collected from the first EN97 vehicle, whose triplets are marked with the numbers 002A and 002B. In addition, table 4 shows the tolerances that must be maintained for individual parameters of the wheel profile.

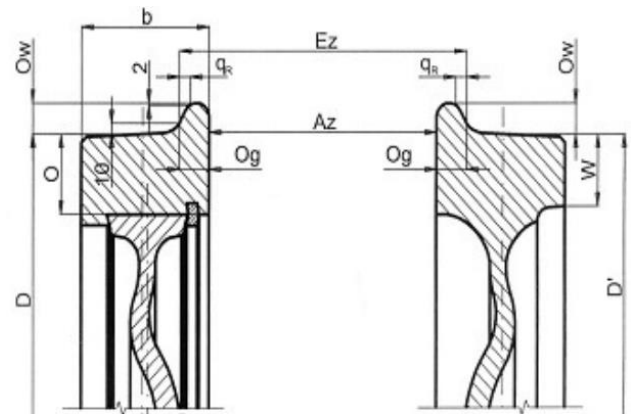

Fig. 4. Cross-section of wheels (rimmed and monoblock) with marked geometrical parameters [6]

The preliminary analysis of the data contained in Table 4 and changes in the wheel diameters of the EN97 vehicle proves the uneven wear of both selected geometrical parameters of the wheelsets found during the P2 inspection, as well as the uneven wear of a given parameter (e.g. wheel diameter) during use expressed by the mileage of the vehicle. The reconnaissance tests required the analysis of 41,712 results of geometrical parameters of wheelsets obtained from the operation of 14 vehicles of the EN97 series over a period of two years. The average number of P2 inspections performed on vehicles in this period (from 2012 to 2014) is 22 inspections. The maximum number of P2 inspections is 30 on the vehicle number 008, and the minimum number of inspections is 18 on the vehicle number 006. A different number of P2 inspections indicates uneven wear of wheelsets running on the same railway line.

3. Test results and analysis

Figure 5a presents a quantitative summary of cases of exceeding a given wheel set parameter with the requirements contained in the Maintenance System Documentation, found during the P2 inspection. The results in Fig. 5a were recorded after a total of 41,712 measurements of wheelsets on 14 vehicles over a period of more than two years. On the other hand, Fig. 5b shows the percentage of exceeding a given parameter of the wheelset related not to all ZK measurements, but only to the measurements of a given parameter. For example, the exceeded wheel diameter in the rolling circle accounts for 12.7% of all wheel diameter measurements, i.e. 7,584, made on 14 vehicles in the same period (over 2 years) during the P2 level review. Figure 6 is a cumulative percentage list of cases of exceeding a given wheel set parameter related to the sum of all exceeding the parameters (D, qR, Og, Ogl+Ogp, Ez, Ow and Az), i.e. 2223 cases characterizing the wheel profile of the tested wheelsets.

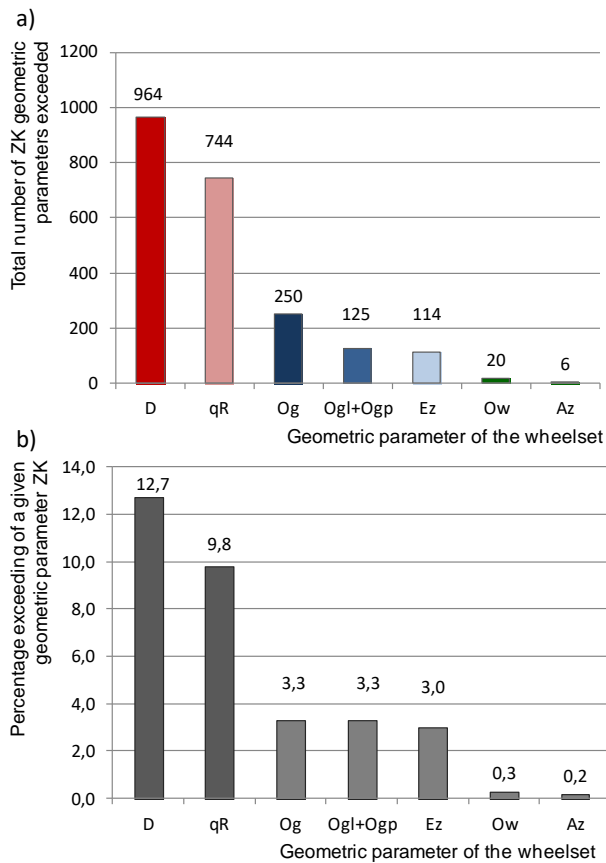

Fig. 5. Summary a) quantitative, b) percentage exceedances of a given wheel set parameter during the P2 inspection for the 14 vehicles tested over a period of 2 years

Both the analysis of the results in terms of quantity and percentage of exceeding the geometrical parameters describing the wheelset proves that, first of all, the wheel diameter in the rolling circle was found most often during the measurements of the wheelset during P2 inspections. According to Fig. 5a, there were almost 1000 cases out of 7584 measurements of wheel diameters over the period of over 2 years of use of electric multiple units. The second place in terms of exceeded parameters to the DSU requirements was the edge steepness qR with the result of almost 750 cases out of 7584 measurements.

The next parameters, the number of exceedances of which were the same or similar, are the thickness of the rim Og, the sum of the thicknesses of the left and right rims Ogl+Ogp and the distance between the outlines of the rims Ez. Although Fig. 5a shows other exceedance values, comparing these results to the number of measurements of a given parameter, which in percentage terms is shown in Fig. 3b), very similar results were obtained. For example, the thickness of the rim with 250 exceedances was found during twice as many measurements, because both the right and left thickness of the rim had to be measured (7584 measurements), in the case of the sum of the thickness of the rims, 125 exceedances were found, and for param-

eter Ez 114 exceedances. These parameters were obtained from one measurement, i.e. from 3792 measurements found during P2 inspections for all vehicles from the same period of use.

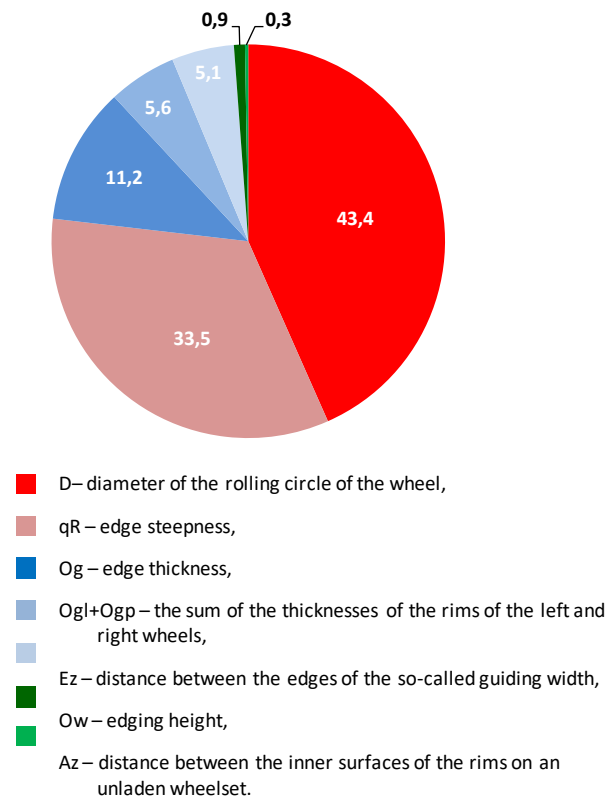

Fig. 6. Percentage of exceeding a given ZK parameter to all exceedances of geometrical parameters found in time P2

As regards the geometrical parameters related to the flange of the wheelset, Figures 7-10 show the total number of crossings beyond the limits included in the DSU for all 14 vehicles of such parameters as the flange height Ow, flange thickness Og, the sum of the thickness of the left and right flanges Ogl+Ogp and the steepness of the flange qR. The above-mentioned parameters with excesses were found during cyclical inspections of the P2 level. On the other hand, Figures 11-13 graphically show the number of exceeded parameter related to the wheel diameter D, the distance between the flange outlines (the so-called guide widths Ez) and Az, i.e. the distance between the inner surfaces of the rim in the wheel set without load. The graphs in Fig. 7-13 refer to all 12 wheelsets of the tested vehicles in such a way that it is possible to observe the exceeded geometrical parameter in relation to the remaining wheelsets. The numbers on the bars of individual wheelsets present quantitatively the cases of exceeding the parameter in all vehicles from the period of two years of use.

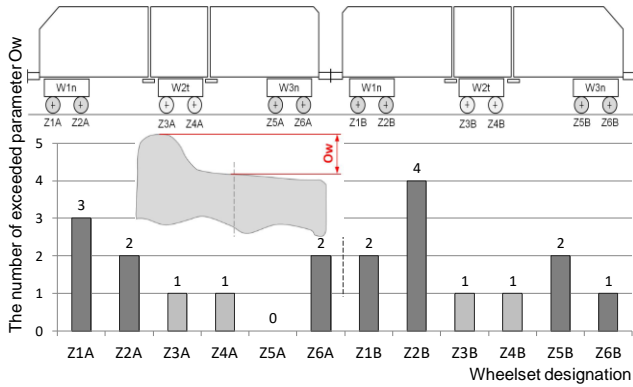

Fig. 7. The number of exceeding the Ow edge height parameter during inspections P2

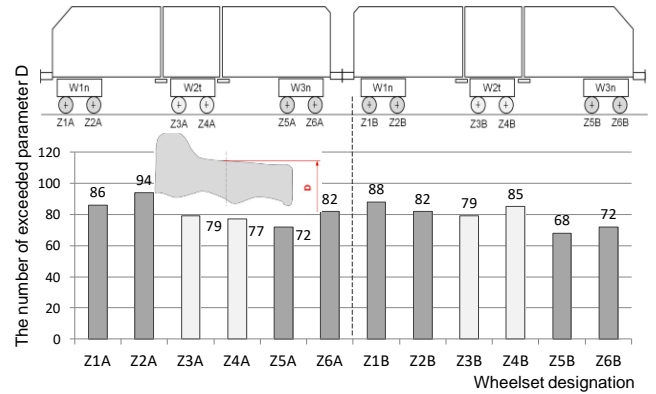

Fig. 11. The number of times the wheel diameter parameter D was exceeded during P2 inspections

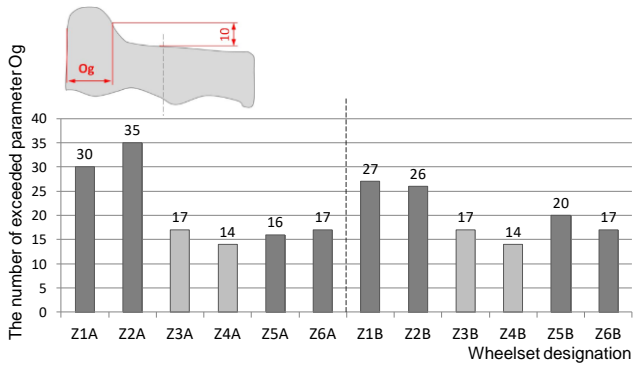

Fig. 8. The number of exceeding the Og edge thickness parameter during inspections P2

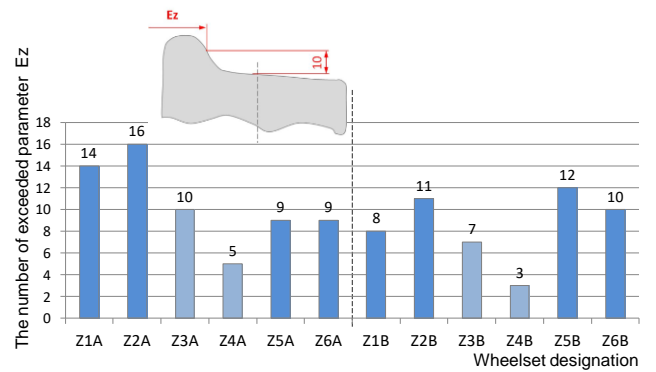

Fig. 12. The number of exceeding the parameter of the distance between the outlines of the outskirts Ez, the so-called guide width found during P2 surveys

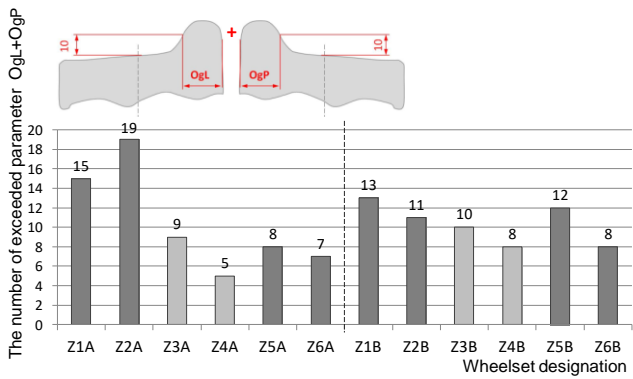

Fig. 9. The number of exceeding the parameter of the sum of the thickness of the rim Ogl+Ogp during inspections P2

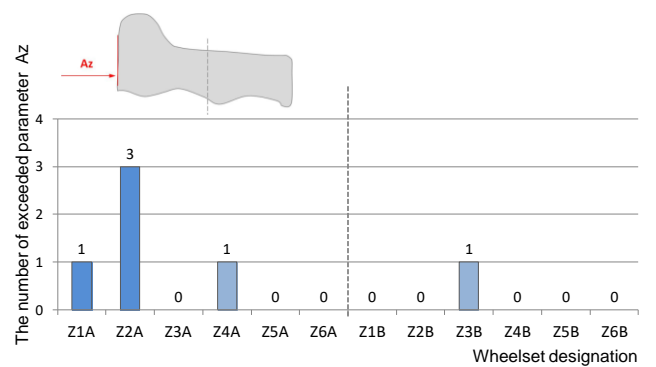

Fig. 13. The number of violations of the parameter of the distance between the inner surfaces of the rims in the unloaded wheelset Az during inspections P2

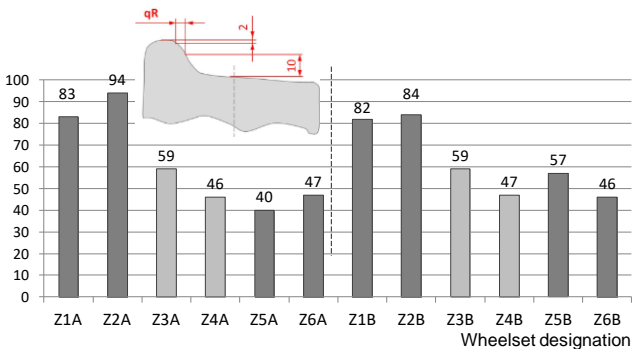

Fig. 10. The number of times the qR edge steepness parameter was exceeded during P2 inspections

Analyzing the graphs presented in Fig. 7–13 of the number of exceedances of the geometric parameters of the tested wheelsets, it is found that the vast majority of the above-mentioned exceedances of parameters took place on the second wheelset of the first section (wheelset Z2A), which was found for 6 out of 7 parameters describing the geometry of the railway wheel. The second place in terms of exceeded geometric parameters was found on the first set of the first (A) and second tripartite of the EN97 Vehicle (wheelsets 1A and 1B), which was observed on 4 out

of 7 analyzed parameters of the wheelsets. The exact list of the most common cases is presented in Table 5.

Table 5. Cumulative number of exceeding the parameters of the wheelset beyond the tolerance limits contained in the DSU, broken down into individual wheelsets of the tested vehicles EN97

Tripartite A						
	Z1A	Z2A	Z3A	Z4A	Z5A	Z6A
D	88	94				82
qR	83	94				
Og	30	35				
Ogl+Ogp	15	19				
Ez	14	16				
Ow	3	2				2
Az	1	3		1		
Tripartite B						
	Z1B	Z2B	Z3B	Z4B	Z5B	Z6B
D	86	82				
qR	82	84				
Og	27	26				
Ogl+Ogp	13	11			12	
Ez		11			12	
Ow	2	4			2	
Az			1			

Note: Colors indicate the intensity of occurrence of a given exceedance on a given wheelset.

In the case of the remaining wheelsets on the rolling middle bogies (3A, 4A, 3B, 4B) and the last driving bogies (5A, 6A, 5B, 6B), a much smaller (almost twice) excess of the given parameter describing the geometry of the wheelset was observed. The obtained results are consistent with the works [1, 7, 9, 12].

By analyzing the obtained results of the parameters describing the geometric profile of the wheel, it was found that exceeding a given parameter is the result of several factors. The first concerns the driver's driving style, while the second concerns the period of use of vehicles divided into autumn-winter and spring-summer periods. Not every vehicle was analyzed in terms of the driving style of a given driver, but the analysis was made in terms of the two mentioned periods of the year. The analyzed data cover a period of

over two years and on this basis it can be unequivocally stated that in the autumn and winter periods the intensity of consumption was much higher than in the spring and summer periods. In particular, this was noticed on the example of changing the diameter of the circle D.

4. Conclusions

The analyzes of the registered geometrical parameters of the wheels during the P2 inspections of 14 EN97 series vehicles operated within two years from their production allowed to rank all parameters of the wheel profile from the most frequently exceeded to the least frequent. Exceeding a given parameter indicated wheel wear in accordance with the requirements contained in the maintenance system documentation and accelerated the rolling of wheels on a wheelset lathe.

From the analyzes carried out on the group of the same vehicles, it was found that the parameters most often exceeded during the P2 periodic inspection are wheel diameter D and rim steepness qR. In the case of wheel diameter, 964 cases of exceeding this parameter were found, and in the case of rim steepness, it was 744 cases out of 7584 measurements. In percentage terms, it was 43% and 33% of all exceeded parameters. In the case of wheel diameters, the dominance of this parameter resulted from both wheel-rail contact (friction wear) and the block brake used [10, 17]. However, the friction brake is not the main brake, but is used in the last phase of braking the electrodynamic brake or during emergency braking. Another parameter that was exceeded in 11% of all exceedances was the thickness of the rim, the remaining parameters did not exceed 5% of exceedances beyond the tolerance limits contained in the documentation of the maintenance system.

The conducted analyzes prove that it is possible to extend the service life of the wheelsets by not rolling the wheel profile and cutting the material. This is only possible when the carrier constantly observes changes in the parameters of the wheel profile. In the case of observing accelerated wear, he disassembled the wheel set from the place (of the trolley where this phenomenon occurs) and put it in the wheel set with the least wear.

Acknowledgements

The investigations were carried out within the Implementation Doctorate Program of the Ministry of Education and Science realized in the years 2021-2025.

Nomenclature

Az	distance between the inner surfaces of the rims in the unladen wheelset	Og	rim thickness
D	rolling circle diameter	Ogl	thicknesses of the rims of the left wheels
DSU	Maintenance System Documentation	Ogp	thicknesses of the rims of the right wheels
EN	Electric Standard-Gauge Multiple Unit	Ow	rim height
Ez	the distance between the edges of the so-called guiding width	qR	rim steepness
		ZK	wheelset

Bibliography

- [1] Adamiec P, Witaszek M, Witaszek K. Wear intensity of tyre steels (in Polish). Scientific Journals of the Silesian University of Technology. Series: Transport. 1998;30:71-78. http://delibra.bg.polsl.pl/Content/50419/BCPS-54956_1998_Intensywnosc-zuzycia.pdf
- [2] Documentation of the 33WE electric traction unit maintenance system (in Polish). Bydgoszcz, 04.2013.
- [3] Documentation (Technical and Operating) of the Electric Multiple Unit Type 33WE. PESA, Bydgoszcz 2011.
- [4] Far M. Technical characteristics of the electric multiple unit type 33WE (in Polish). Institute of Rail Vehicles. Poznań 2011.
- [5] Firlik B, Staśkiewicz T. Challenges and opportunities of tram wheel profile design. Proceedings of the Fifth International Conference on Railway Technology: Research, Development and Maintenance. Montpellier 2022.08.22-25. <https://www.ctresources.info/ccc/paper.html?id=9652>
- [6] Instruction MKT-9. Instructions for measurements and technical assessment of traction vehicle wheel sets (in Polish). Majkoltrans Sp. z o.o. Wrocław 2018.
- [7] Konowrocki R, Chojnacki A. Analysis of rail vehicles' operational reliability in the aspect of safety against derailment based on various methods of determining the assessment criterion. Eksploat Niezawodn. 2020;22(1):73-85. <https://doi.org/10.17531/ein.2020.1.9>
- [8] Kortas P. ENRail vehicals wheels wear and re-profiling (in Polish). Scientific Journals of the Silesian University of Technology. Series: Transport. 2013; 79:61-69. <http://yadda.icm.edu.pl/baztech/element/bwmeta1.element.baztech-1adc48c8-ec89-4e8a-ad44-98aa72e34885/c/Kortas.pdf>
- [9] Kowalski S, Lachowski P. Selected damage and wear of wheelsets of rail vehicles (in Polish). Autobusy – Technika, Eksploatacja, Systemy Transportowe. 2018; 12:480-485. <https://doi.org/10.24136/atest.2018.437>
- [10] Kustos J, Goliwas D, Kaluba M. A tool for calculating braking distances of rail vehicles. Rail Vehicles/Pojazdy Szynowe. 2022;3-4:15-19. <https://doi.org/10.53502/RAIL-156462>
- [11] Kwaśnikowski J, Małdziński L, Borowski J, Firlik B, Gramza G. Analysis of the causes of accelerated wear of the rolling surfaces of the SA 108 (215M) rail bus wheels (in Polish). Rail Vehicles/Pojazdy Szynowe. 2007;2:1-13. <https://doi.org/10.53502/RAIL-139844>.
- [12] Madej J. Analysis of the traction efficiency of a set of wheels of a rail vehicle in a curve of a track with a small radius (in Polish). Rail Vehicles/Pojazdy Szynowe. 2008;1:1-6. <https://doi.org/10.53502/RAIL-139856>.
- [13] Michnej M. Fretting ware process in swivel jointson example of automatic whellset gauge changing system (in Polish). Technical Journal. Publishing House of the Cracow University of Technology. 2012;14:159-166. https://repozytorium.biblos.pk.edu.pl/redo/resources/31358/file/suwFiles/MichnejM_ProcesZuzycia.pdf
- [14] Piec P. Analysis of wear wheel rim wheelsets rail vehicles (in Polish). Logistyka. 2014;3:5060-5068.
- [15] Piec P. Study operational wear of wheel sets of rail vehicles in the aspect holistic tribology (in Polish). Logistyka. 2015;6:1235-1250.
- [16] Raport roczny WKD 2021/Annual Report (in Polish). Kolej Samorządowa. <https://www.wkd.com.pl/o-wkd/raporty/raporty/2884-2021>
- [17] Sawczuk W, Cañas Rilo AM. The issues of hot-spots type in the railway disc brake. Rail Vehicles/Pojazdy Szynowe. 2021;1:33-43. <https://doi.org/10.53502/RAIL-138492>
- [18] Słowiński MS. Materials used in the construction of rail vehicle wheels. Rail Vehicles/Pojazdy Szynowe. 2021;4:14-24. <https://doi.org/10.53502/RAIL-144535>
- [19] Słowiński MS. The characteristics of the selected types of wheel wear and their effect on the rail vehicle – track interaction. Rail Vehicles/Pojazdy Szynowe. 2022;1-2:3-9. <https://doi.org/10.53502/RAIL-147440>
- [20] Sobaś M. Wheel wear during the operation of rail vehicles. Causes and effects. Rail Vehicles/Pojazdy Szynowe. 2021;2:16-28. <https://doi.org/10.53502/RAIL-139979>
- [21] Zbieć A. Causes of uneven wear of wheelsets in freight wagons (in Polish). Prace Instytutu Kolejnic-twa. 2017;155:43-47.